

Ethernet Switch in 3U Eurocard Format

CR-503

User Manual

Version 1.0

13.09.2016

Developer and manufacturer: LLC Parabel

Russia, 630090, Novosibirsk -90, p/b 126

<http://www.parabel.ru>

Email: info@parabel.ru

Phone/fax: +7-383-2138707

Attention! The device cannot be used with communication lines having no lightning proofness and running outside the limits of one building

Content

1.INTRODUCTION	6
2. SWITCH STRUCTURE	7
3. SWITCH CONNECTION	8
3.1. Connecting ports	8
3.2. Connecting power supply	9
4. DEVICE CONFIGURATION	10
4.1. Mode selection	10
4.2. Unmanaged switch mode	12
4.3. Ethernet tap	12
4.4. VLAN switch mode	14
5. SCOPE OF SUPPLY	16

1.INTRODUCTION

CR-503 is an Ethernet switch in the format of a 3U Eurocard (according to the mechanical standards of IEEE 1101.1 and IEEE 1101.11). The device has 5 Gigabit Ethernet ports and can be used in several modes: as an unmanaged general-purpose switch, as a switch with VLAN functions, or an Ethernet tap. The board format allows installing the device to the expansion slots of crates CompactPCI, PXI, VME, VME64 and other bus-structured modular systems complying with IEEE 1101.1 standard. If necessary, the switch can be installed on the place of the Rear transition board. The scope of application of the switch is the communication expansion module in control and automation systems.

The adapter has the following characteristics:

- Form factor – 3U Eurocard, 80 mm long, IEEE 1101.1.
- 5 ports 10/100/1000 Base-T with decoupling 1500V
- Full/Half duplex with flow control support IEEE 802.3x
- Support of jumbo frames of 9216 bytes
- Polarity and entangled pairs self-correction
- Support of IEEE 802.1Q VLAN
- Support of Spanning Tree IEEE 802.1w, IEEE802.1s
- 3 modes – unmanaged switch, VLAN switch, Ethernet tap.

2. SWITCH STRUCTURE

The switch structure is shown in the picture.

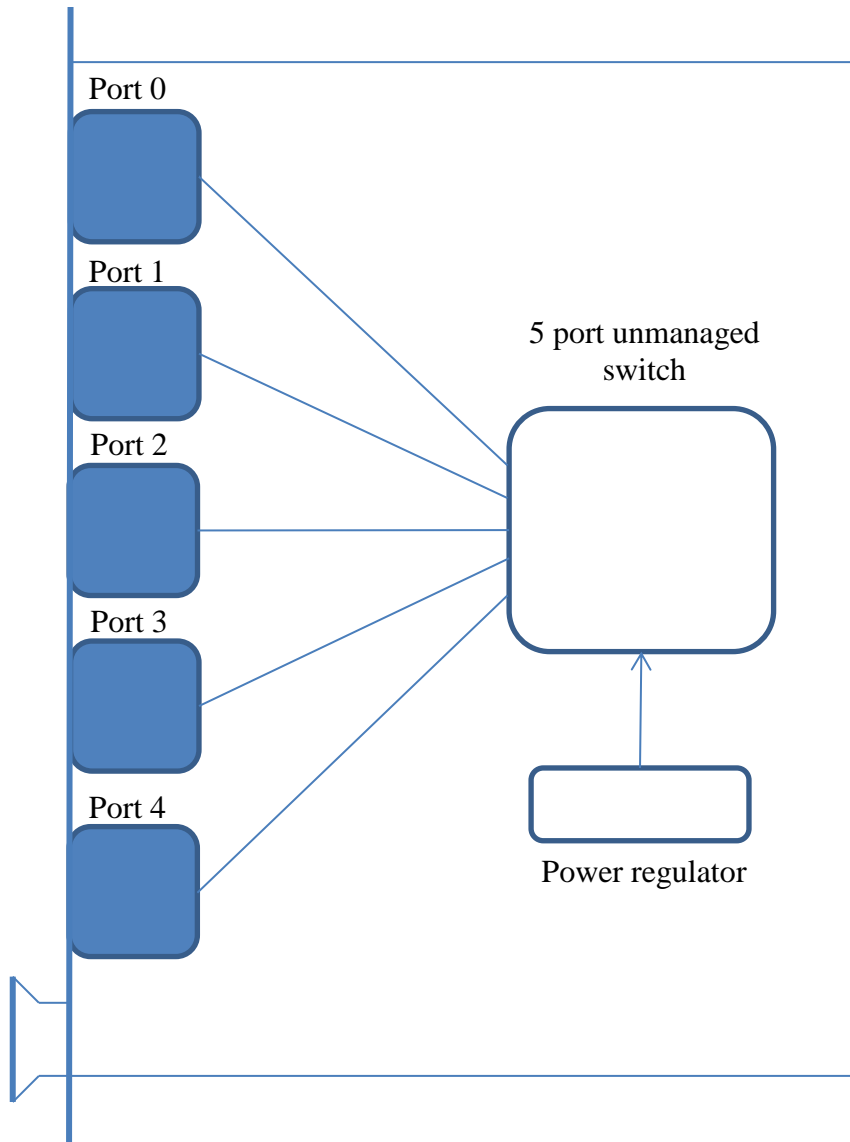

The device is based on 5-port switch RTL8367, which ports 0-4 are put to the front panel of the board.

3. SWITCH CONNECTION

3.1. CONNECTING PORTS

Below you can find the picture of the front panel of CR-503 switch and the table of the ports connection.

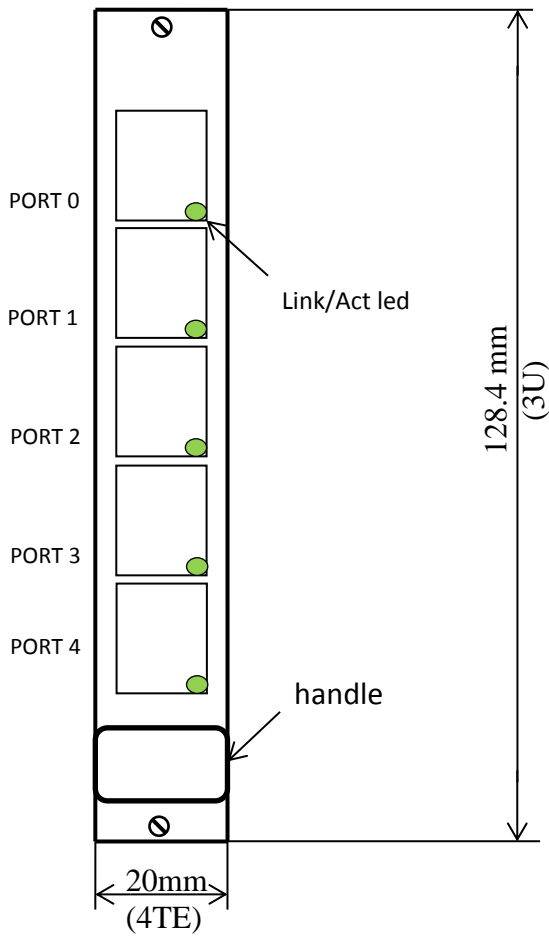

Used connection type RJ-45

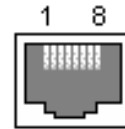

Notes.

1. A,B,C,D – duplex twisted-pair wires
2. Standard 10/100 uses pair A for transmission and pair B for receipt
3. LINK/ACT LED – signal presence and packet transmission/receipt indicator

Output	1	2	3	4	5	6	7	8
Destination	A+	A-	B+	C+	C-	B-	D+	D-

3.2. CONNECTING POWER SUPPLY

The switch is powered via P1 socket with the help of the power supply cable in the scope of supply. The power tension shall be between +5 and +12V. As a power connection point you can use VME/CPCI backplane or free terminals of the crate power supply block. The device is protected from wrong polarity by a diode and a fuse.

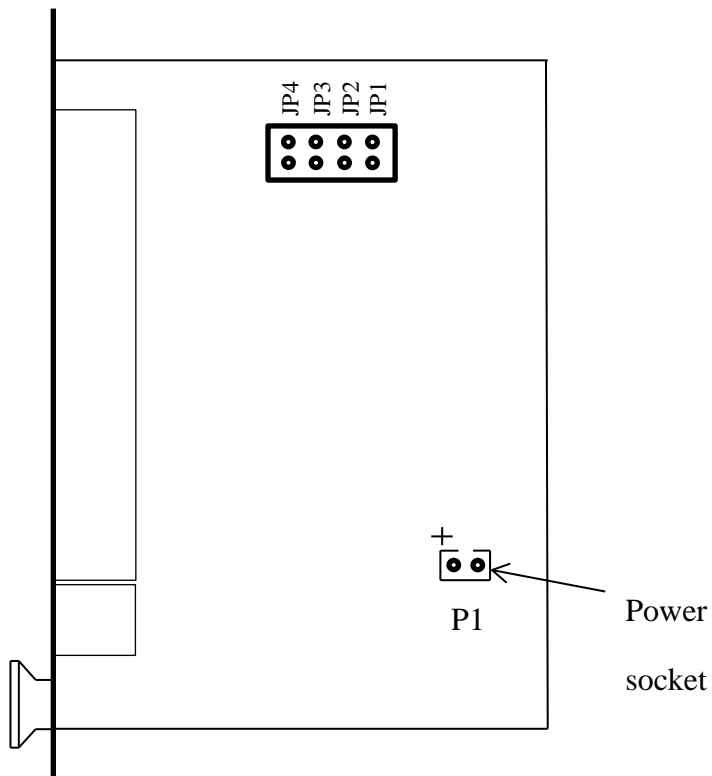

4. DEVICE CONFIGURATION

4.1. MODE SELECTION

The mode is selected with the help of jumpers on board (see the picture).

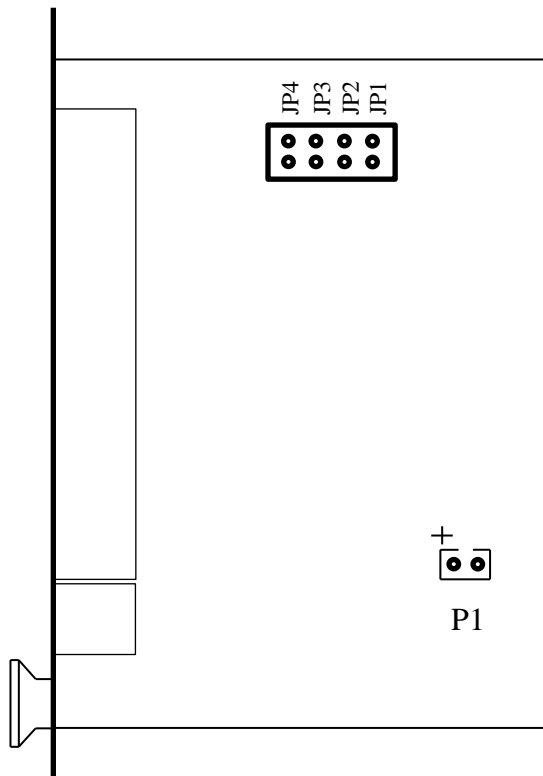

The mode dependence on jumpers position is shown in the table below. On – the jumper is closed, Off – the jumper is open, X – the position is ignored.

JP4	JP3	JP2	JP1	Mode
Off	Off	X	X	5-port unmanaged switch
Off	On	X	X	Ethernet tap
On	X	Off	Off	VLAN switch, N=200
On	X	Off	On	VLAN switch, N=300
On	X	On	Off	VLAN switch, N=400
On	X	On	On	VLAN switch, N=500

N – internal VLAN identifier (see mode description).

4.2. UNMANAGED SWITCH MODE

In this mode the device is used as a general-purpose 5-port non-blocking switch with 2K table of MAC addresses.

4.3. ETHERNET TAP

In this mode the device still functions as a switch, but port 0 and port 4 perform special purposes. A peripheral device with traffic to analyze can be connected to port 0. Using ports 1-3 the device to be analyzed will carry out outward communication. But the packets sent or received via port 0 will be copied to port 4 and sent to the monitoring computer. With the help of a network analyzer these packets can be recorded and analyzed.

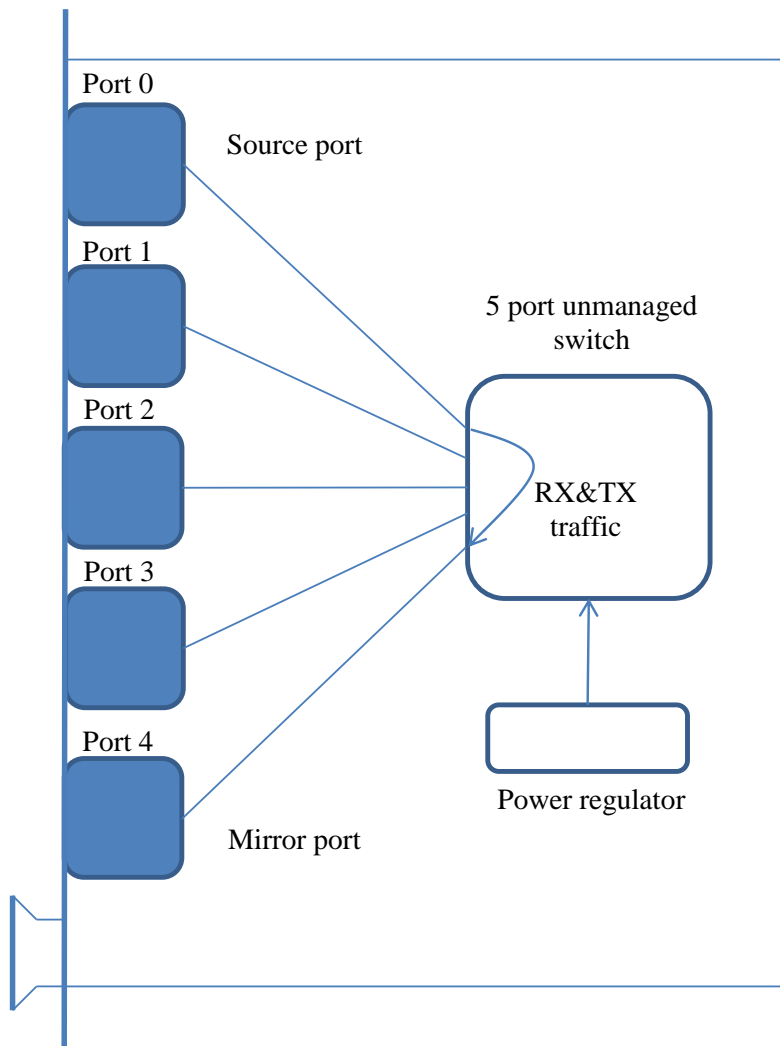

The example of the Ethernet tap mode performance is shown in the picture below.

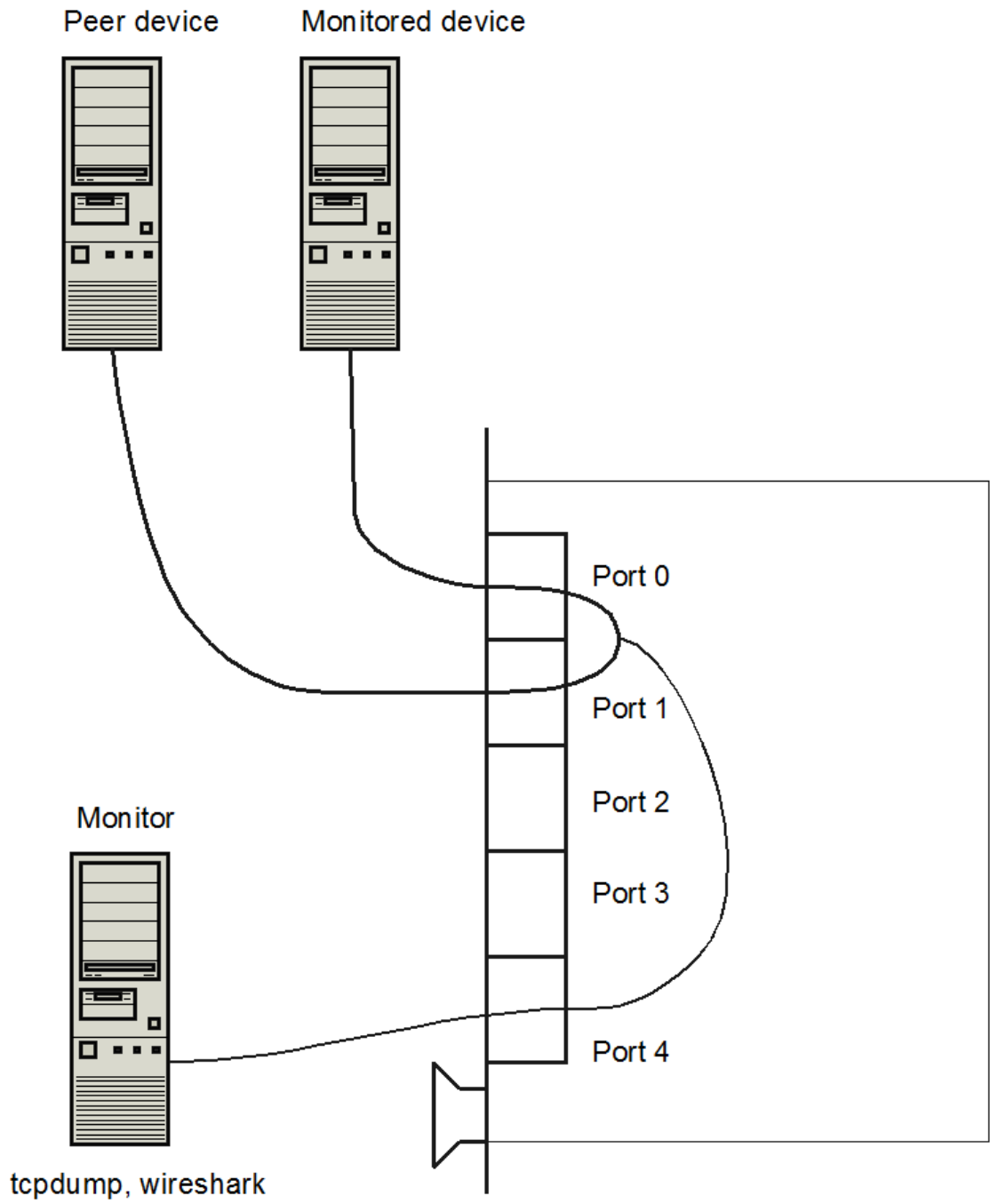

4.4. VLAN SWITCH MODE

In this mode 4 VLANs with numbers $N..N+3$ are created in the switching matrix of the device. Ports 0..3 are members of VLANs $N..N+3$ correspondingly and transmit non-tagged traffic. Port 4 is member of the four VLANs and transmits tagged traffic, a packet is assigned the VLAN tag, corresponding the receipt port number. Using such a configuration a computer connected to port 4 can select its destination port with a VLAN number. Devices with no VLAN support are connected to ports 0..3.

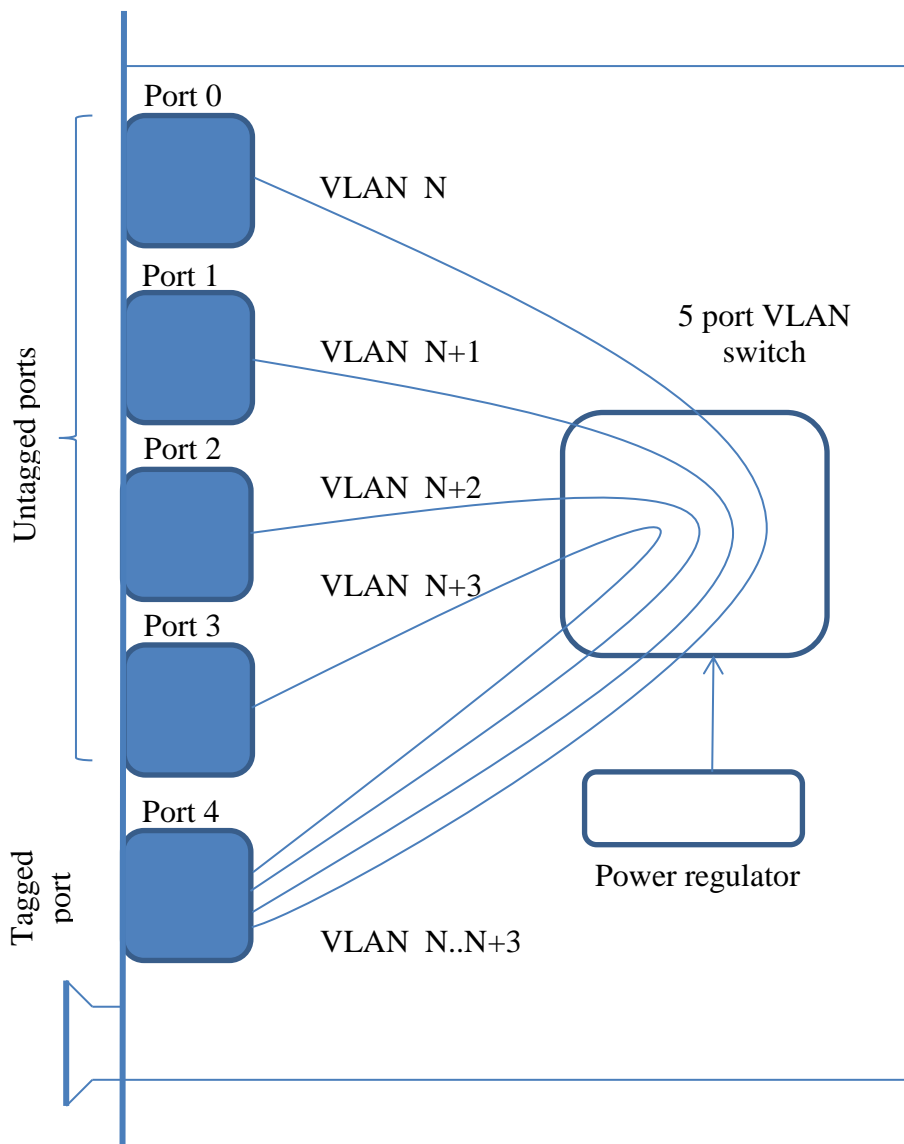

Tag N value is assigned by jumper configuration.

An example of VLAN mode application is shown in the picture.

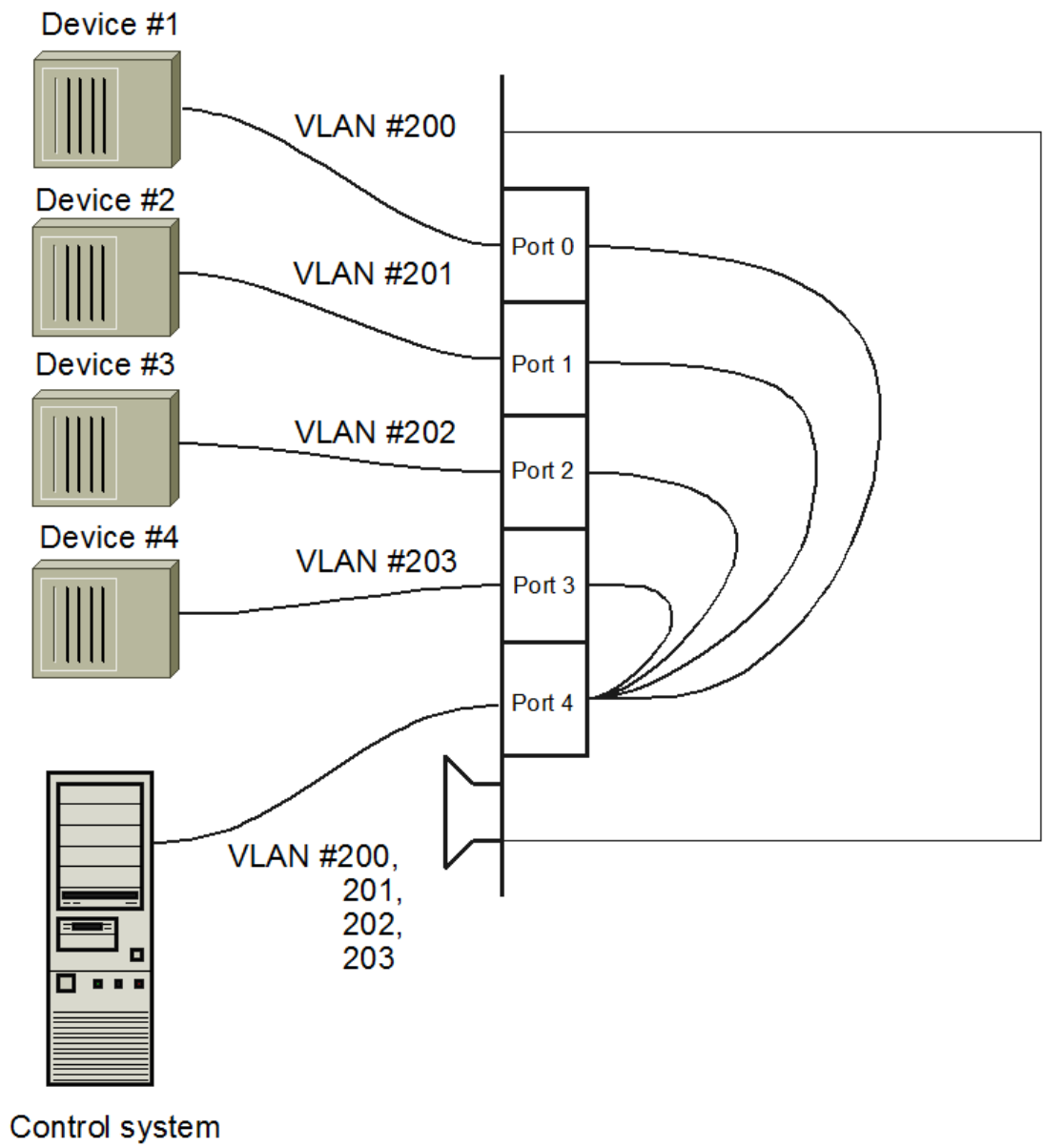

5. SCOPE OF SUPPLY

- Switch board
- CD with user's manual
- Certificate of warranty
- Packing box

The set weight is not over 0.5 kg.

